

REV.	DATE	DESCRIPTION	DRAWN BY	CHECKED BY
0	2022.FEB.15	INITIAL RELEASE	VK	KW

ITEM	PART	DESCRIPTION	MATERIAL	FINISH	QTY.
1	EC36-GASKET-EXT	WEDGE GASKET (EXTERIOR)	EPDM	EX WORKS	1
2	EC36-GASKET-INT	BACKER GASKET (INTERIOR)	EPDM	EX WORKS	1
3	PC2108-P01	PERIMETER CHANNEL 2108-P01	ALUMINUM 6063-T6	CLEAR ANODIZED	1
4	A0006	GLAZING CLIP	ALUMINUM 6063-T6	CLEAR ANODIZED	1

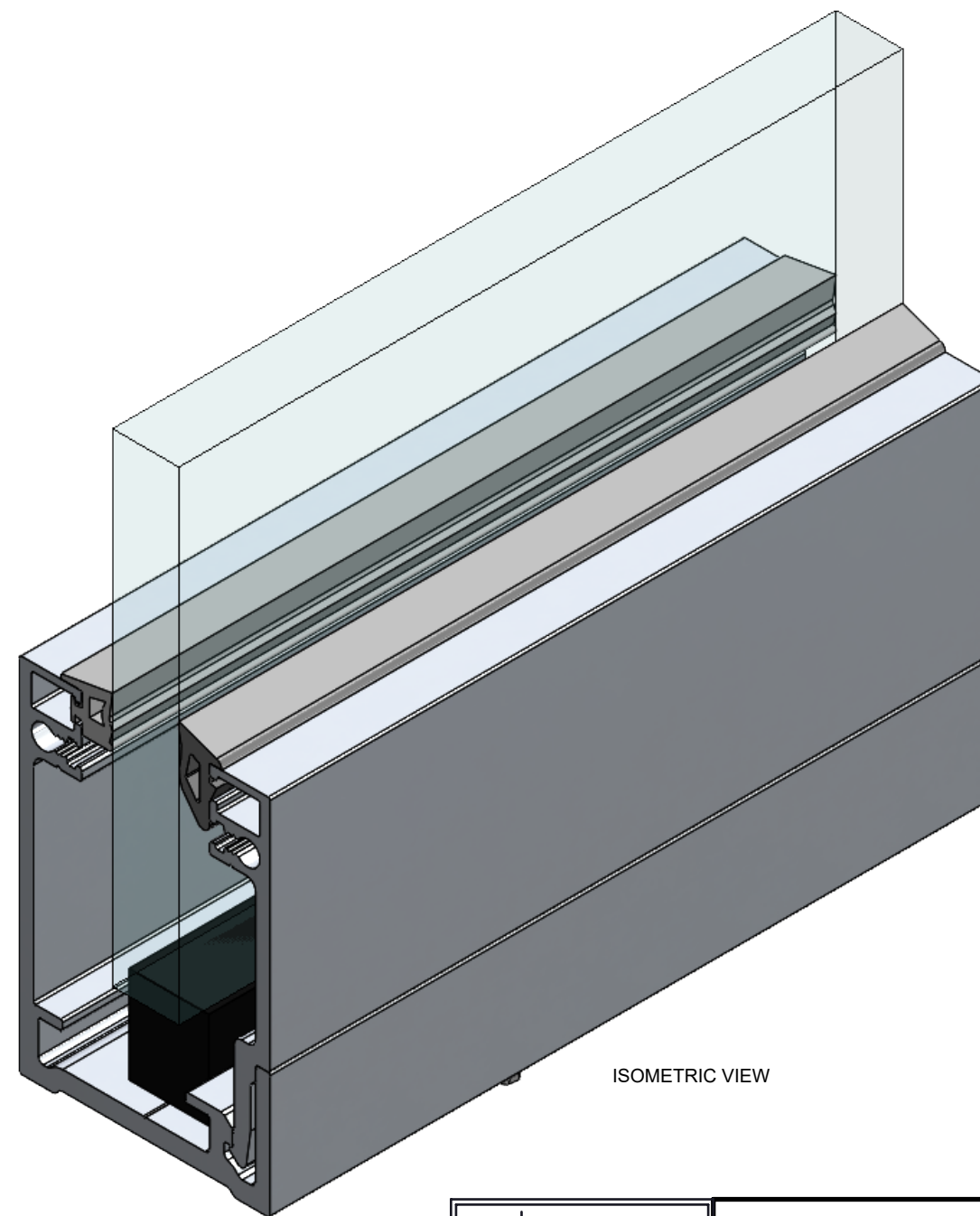
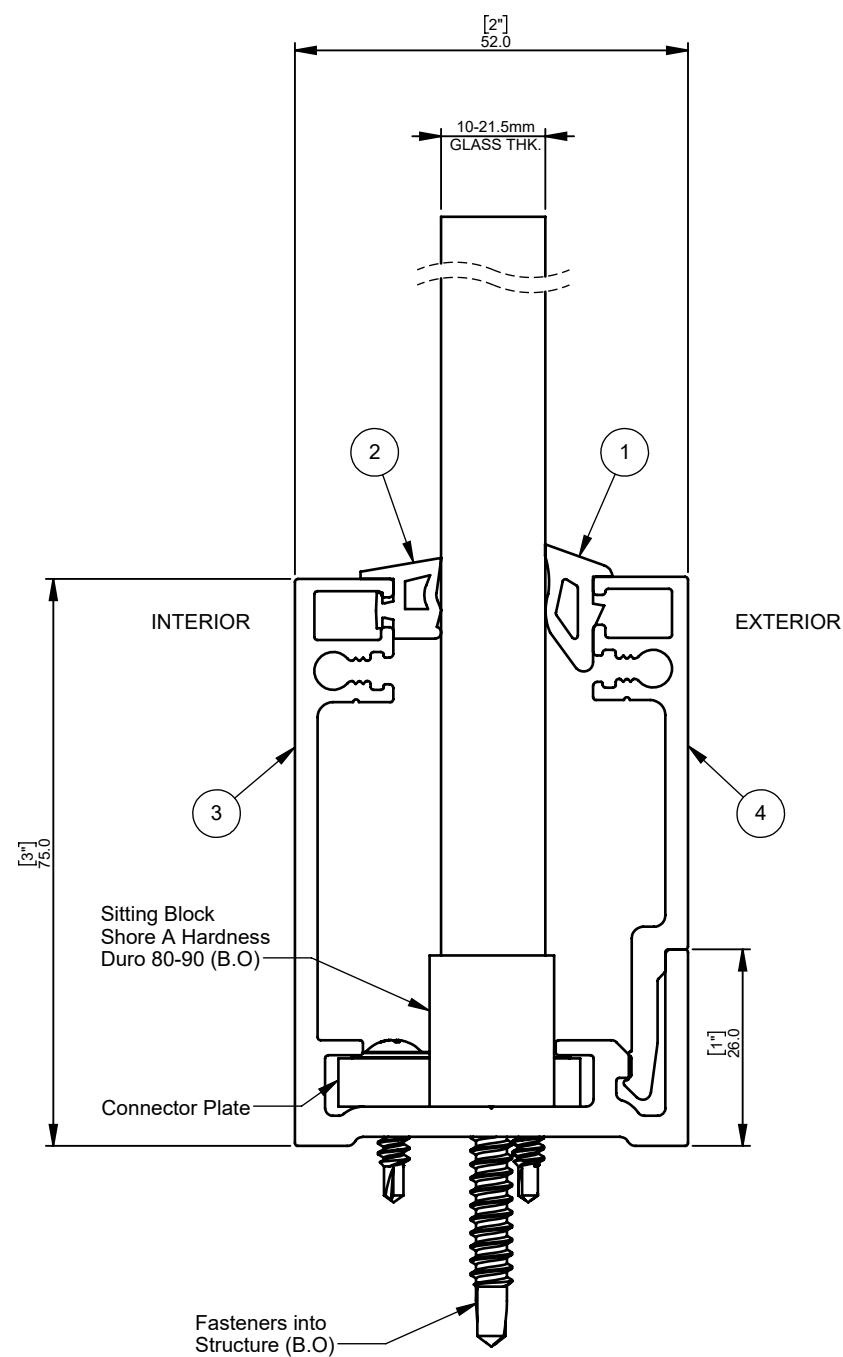

FRONT VIEW

ISOMETRIC VIEW

- NOTES:**
1. ALL DIMENSIONS ARE IN MILLIMETERS (mm) UNLESS SPECIFIED.
 2. DIMENSION IN [] ARE IN INCHES.
 3. REFER PART DRAWINGS FOR MORE DETAILS.

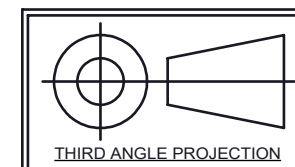

UNIT 105-8218 NORTH FRASER WAY, BURNABY, BC, V3N 0E9
 TEL (604) 231 5892 WWW.STELLAGLASSHARDWARE.COM

ASSEMBLY DRAWING
PERIMETER CHANNEL PC2108

SCALE

1:1

DWG No

PC2108

This drawing is the property of Stella Custom Glass Hardware Inc and may not be copied or reproduced in any way whatsoever without written permission of that company