

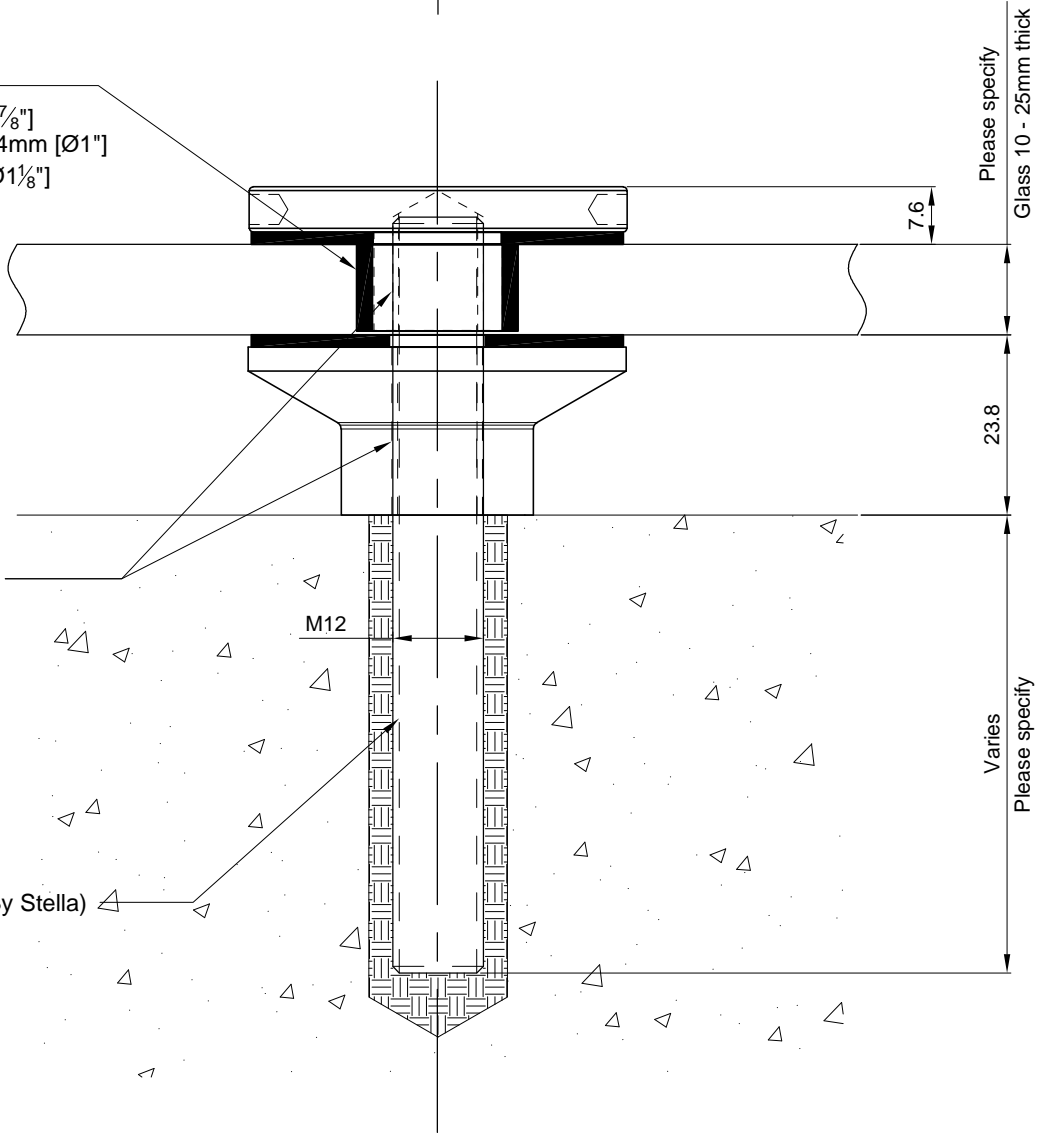

Hole in glass  
 min.  $\text{Ø}22.2\text{mm}$  [ $\text{Ø}\frac{7}{8}"$ ]  
 recommend  $\text{Ø}25.4\text{mm}$  [ $\text{Ø}1"$ ]  
 max.  $\text{Ø}28.6\text{mm}$  [ $\text{Ø}1\frac{1}{8}"$ ]



Loctite Type 243  
 all threads during  
 site installation  
 (By others)

M12x1.75 Stud (By Stella)  
 Epoxy (By others)

REV 1 - Loctite type 243 notes added & title updated - 20160422

Quantity: Sets Material: Grade 316 Stainless steel Finish: Machined	Hole in glass above Dimensions millimeter unless otherwise shown 4mm hole can be tighten w/ pin "C" spanner (Ref. SPA-02)  Subject to change	Drawn JH Checked RL	Drawn date OCT 26-09 Checked date OCT 26-09	
		Scale 1:1	Rev. 1	
<b>ASSEMBLY DRAWING</b> <b>STANDOFF ST505F-C W/ FLAT FRONT PLATE &amp;</b> <b>M12 STUD EMBEDDED INTO CONCRETE - FORMALLY NB4-A13</b>		DWG No ST505F-C		
		[i] (604) 231 5892 [f] (604) 231 5893 [e] info@stellaglasshardware.com		