

FRONT VIEW

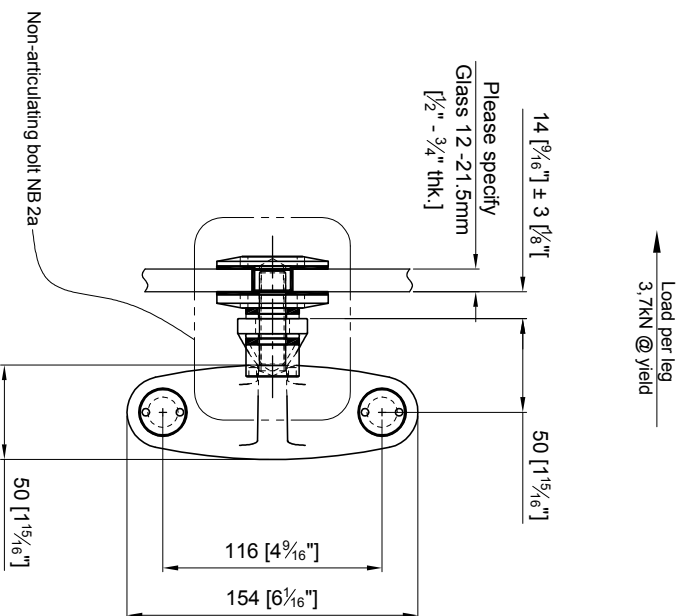

SIDE VIEW

Quantity: Sets
Material: Grade 304/316 Stainless steel
Finish: Spider: Satin; Glass bolt: Machined

Hole in glass min. Ø22.2mm [Ø 7/8\"/>

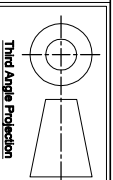

| Drawn | Drawn date |
|----------|----------------|
| JH | NOV 18-09 |
| Approved | Approved date |
| RL | NOV 18-09 |
| Scale | Rev. |
| 1:4 | - |
| DWG No | SS202ST-NB601T |

ASSEMBLY DRAWING
S20-2Sa SIDE MOUNTED SPIDER W/ NON-ARTICULATING BOLT NB2a
FORMALLY S20-2Sa-NB2a

APPROVAL

DATE



This drawing is the property of Stella Custom Glass Hardware Inc and may not be copied or reproduced in any way whatsoever without written permission of that company