

FRONT VIEW

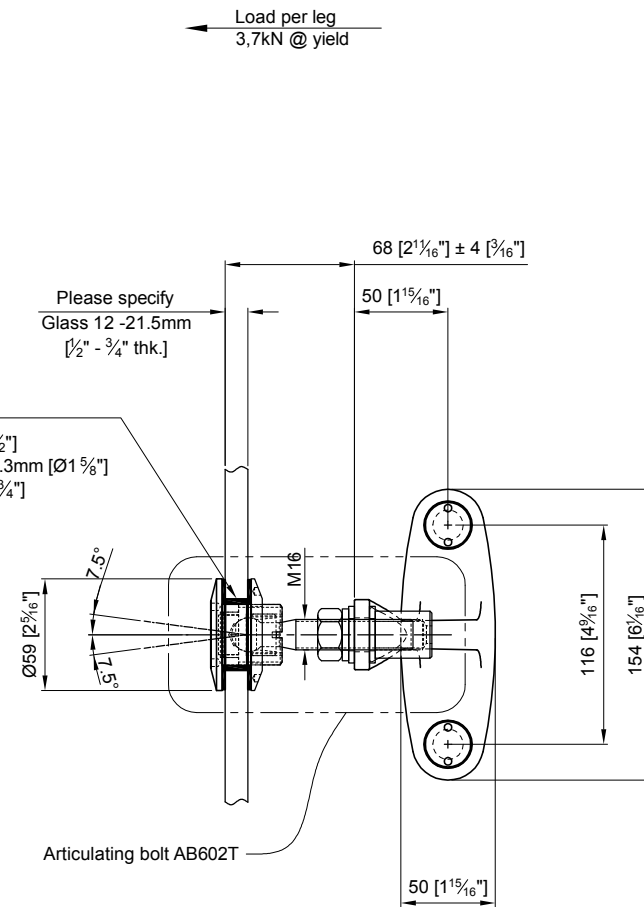

SIDE VIEW

APPROVAL
DATE

Quantity: Sets
Material: Grade 304/316 Stainless steel
Finish: Spider: Satin; Glass bolt: Machined

Hole in glass see above
Dimensions millimeter unless otherwise shown
Apply loctite 243 to all threads during assembly
(To increase curing speed, please apply activator 7649)
Details are typical and are subject to change to meet project requirement

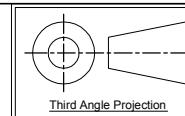

Drawn	Drawn date
JH	JAN 17-2013
Approved	Approved date
Scale	Rev.
1:4	-
DWG No	
SS201ST-AB602T	



ASSEMBLY DRAWING
SS201ST SINGLE ARM SIDE MOUNTED SPIDER W/ ARTICULATING BOLT AB602T