

FRONT VIEW

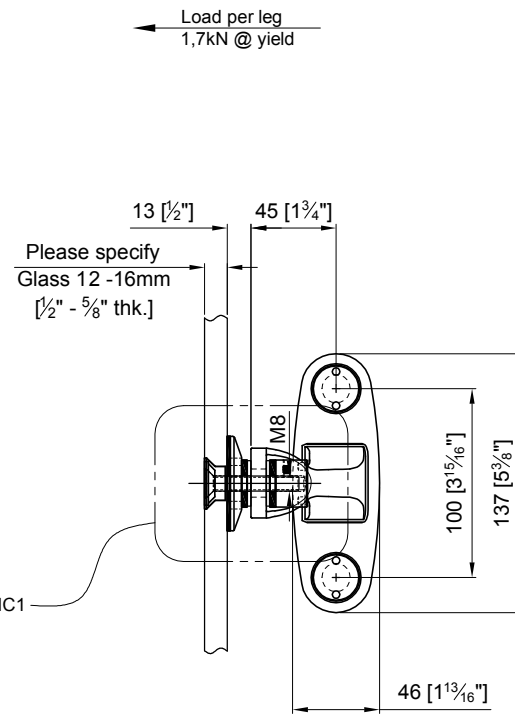

SIDE VIEW

APPROVAL
DATE

Quantity: Sets
Material: Grade 304/316 Stainless steel
Finish: Spider: Satin; Glass bolt: Machined

Hole in glass Ø19.1 [3/4\"] & Csk to suit ferrule bushing NC1-P04
 Dimensions millimeter unless otherwise shown
 Apply loctite 243 to all threads during assembly
 (To increase curing speed, please apply activator 7649)
 Details are typical and are subject to change to meet project requirement

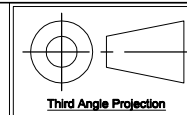

Drawn	Drawn date
JH	JAN 6-2010
Approved	Approved date
RL	JAN 6-2010
Scale	Rev.
1:4	-
DWG No	
SS151ST-NB501C	

stella
 custom glass hardware Inc
 [t] (604) 231 5892
 [f] (604) 231 5893
 [e] sales@stellassemblies.com

ASSEMBLY DRAWING
 S15-1Sa SIDE MOUNTED SPIDER W/ NON-ARTICULATING BOLT NC1
 FORMALLY S15-1Sa-NC1