

Load per leg
0,8kN @ yield

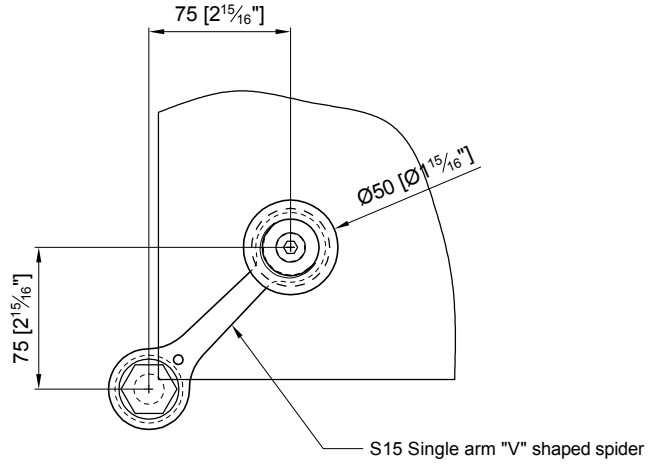

FRONT VIEW

Load per leg
1,5kN @ yield

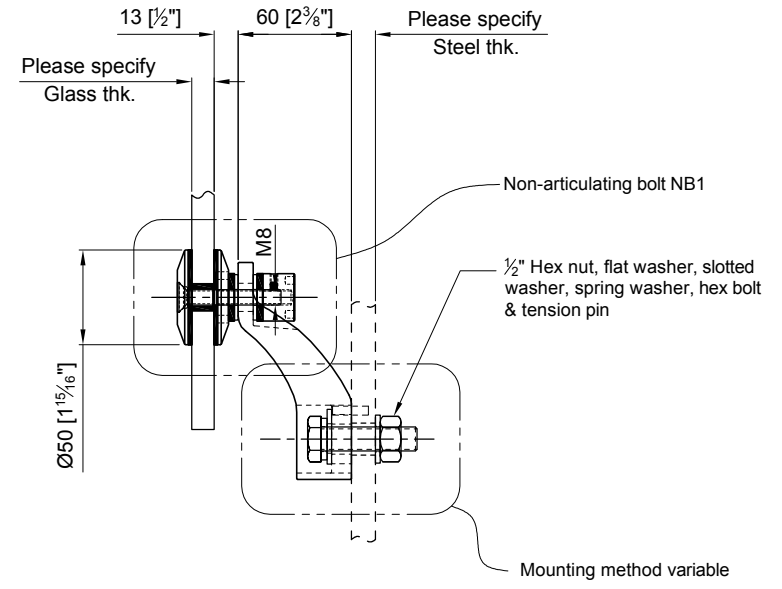

SIDE VIEW

APPROVAL
DATE

Quantity: Sets
Material: Grade 304/316 Stainless steel
Finish: Spider: Satin; Glass bolt: Machined

Hole in glass min. Ø15.9mm [Ø 5/8"]
Dimensions millimeter unless otherwise shown
Apply loctite 243 to all threads during assembly
(To increase curing speed, please apply activator 7649)
Details are typical and are subject to change to meet project requirement

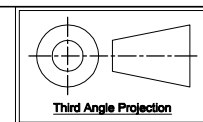

Drawn	Drawn date
JH	NOV 18-09
Approved	Approved date
RL	NOV 18-09
Scale	Rev.
1:4	-
DWG No	
SS151FV-NB501T	

stella
custom glass hardware Inc
[t] (604) 231 5892
[f] (604) 231 5893
[e] sales@stellassemblies.com

ASSEMBLY DRAWING
S15-1Va "V" SHAPED SPIDER W/ NON-ARTICULATING BOLT NB1
FORMALLY S15-1Va-NB1