

Load per leg  
0,8kN @ yield

Load per leg  
1,5kN @ yield

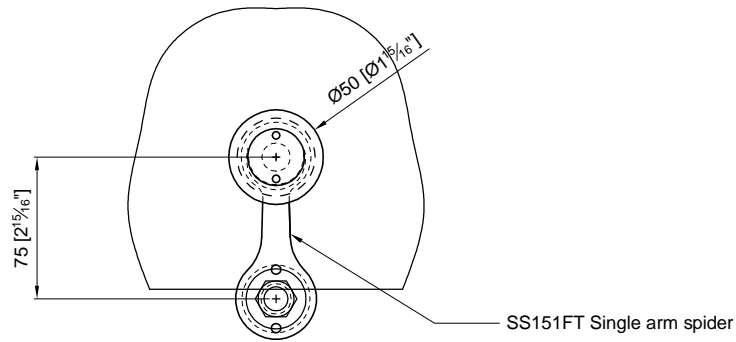

FRONT VIEW

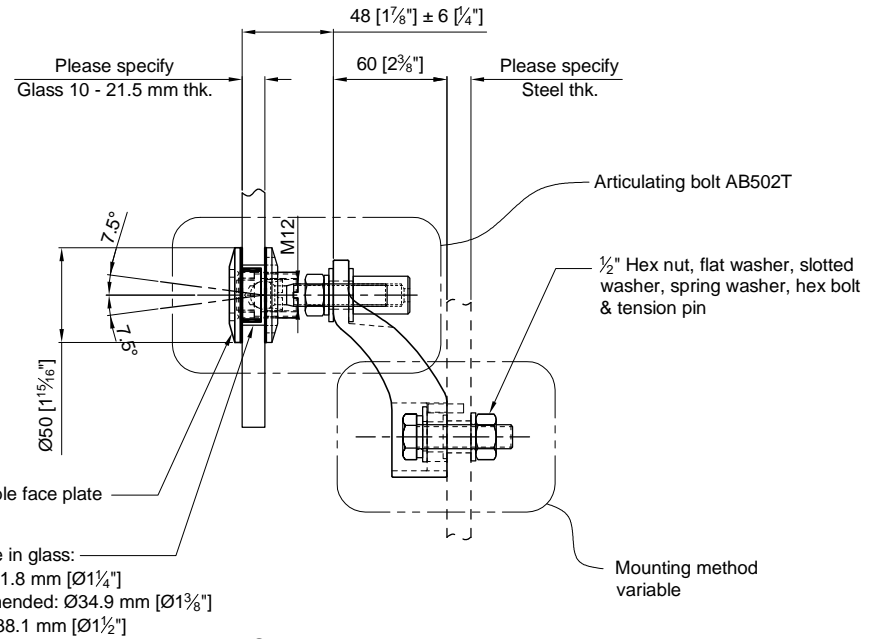

SIDE VIEW

Thru hole in glass:  
min: Ø31.8 mm [Ø1 1/4\"/>  
recommended: Ø34.9 mm [Ø1 3/8\"/>  
max: Ø38.1 mm [Ø1 1/2\"/>

APPROVAL
DATE

Quantity: Sets  
Material: Grade 316 Stainless steel  
Finish: Spider: Satin; Glass bolt: Machined

Hole in glass see above  
Dimensions millimeter unless otherwise shown  
Apply loctite 243 to all threads during assembly  
(To increase curing speed, please apply activator 7649)  
Details are typical and are subject to change to meet project requirement

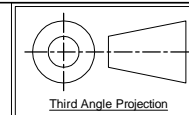

Drawn	Drawn date
JH	JAN 22-2013
Approved	Approved date
Scale	Rev.
1:4	-
DWG No	
SS151FT-AB502T	

**stella**  
[t] (604) 231 5892  
[f] (604) 231 5893  
[e] info@stellaglasshardware.com

ASSEMBLY DRAWING  
SS151FT SPIDER W/ FACE MOUNTED ARTICULATING BOLT AB502T