

Quantity:
Material: ALUMINUM 6063-T6
Finish: ANODIZED AND BRUSHED LIKE SS

REVISIONS
1. 17-03-20 - PARTS RENUMBERED - RL

Drawn	Drawn date
JT	SEPT 07-16
Checked	Checked date
Scale	Rev.
1:1	1
DWG No	
PGA21BA	

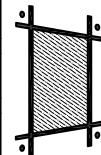

stella

[t] (604) 231 5892
[f] (604) 231 5893
[e] info@stellaglasshardware.com

ASSEMBLY DRAWING
POSIGLAZE - GUARD SUPPORT SYSTEM
BASE MOUNTED - FOR GLASS THK. 20 - 21.5mm

S:\PRODUCTS\POSIGLAZE\Engineering and Design\Development\PG01 - PosiGlaze Assembly Drawings.dwg, 20/03/2017 10:42:34 AM, DWG To PDF.pc3

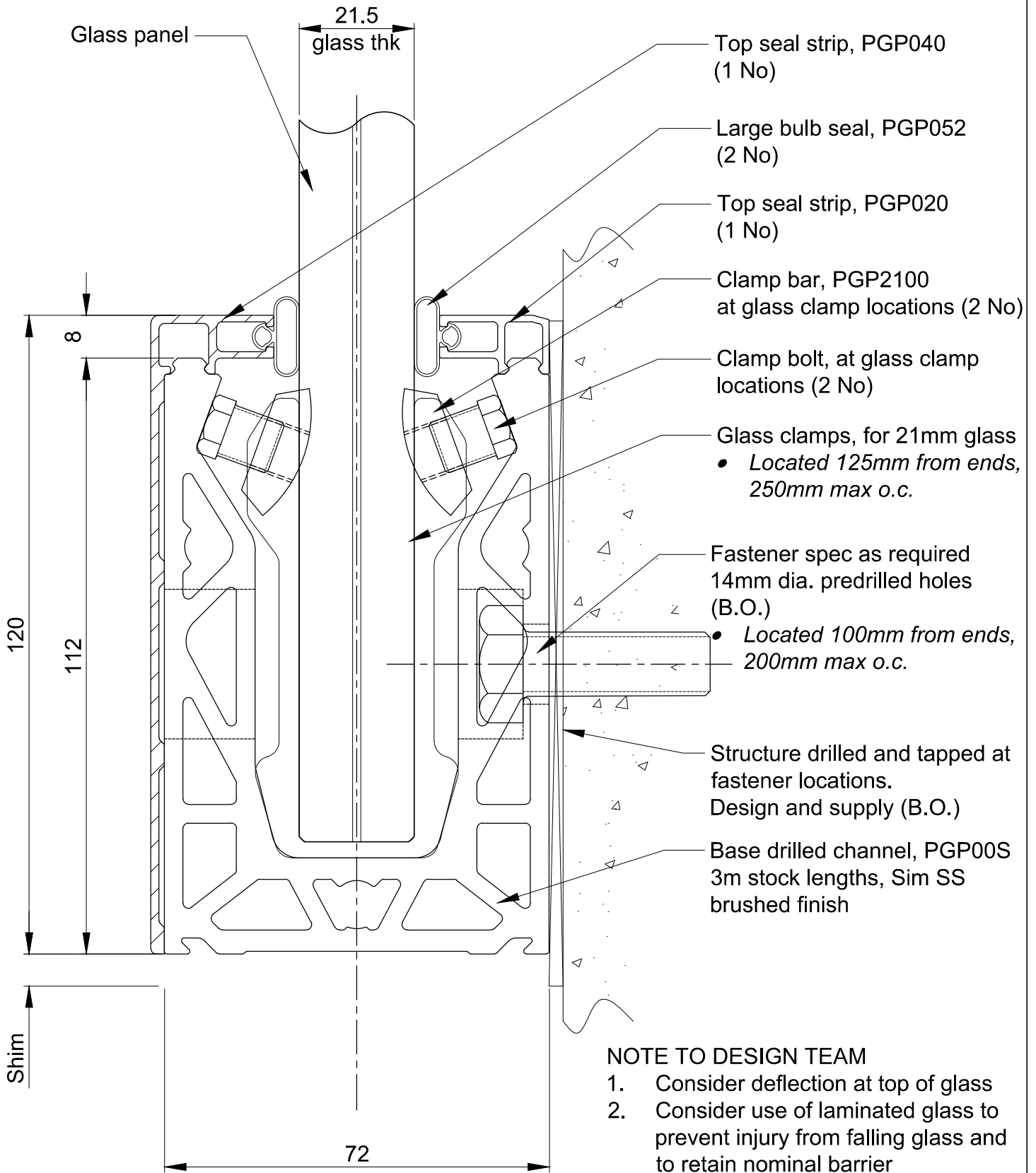

NOTE TO DESIGN TEAM

1. Consider deflection at top of glass
2. Consider use of laminated glass to prevent injury from falling glass and to retain nominal barrier

Quantity:
Material: ALUMINUM
Finish: BRUSHED (LOOKS LIKE S/STEEL)

Drawn	Drawn date
RL	MAR 20-17
Checked	Checked date
Scale	Rev.
1:1	-
DWG No	
PGA21SA	

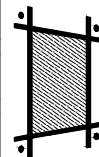

stella

[t] (604) 231 5892
[f] (604) 231 5893
[e] info@stellaglasshardware.com

**ASSEMBLY DRAWING
POSIGLAZE - GUARD SUPPORT SYSTEM
SIDE MOUNTED - FOR GLASS 21.5mm THK**